

# TFIX-8P Facade fixing with plastic pin

Versatile hammer-in facade fixing with plastic nail recommended for ETICS

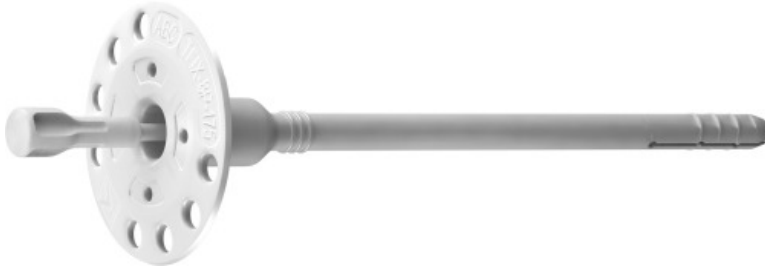

## Approvals and Reports

- ETA-13/0845



## Product information

### Features and benefits

- Installation in all base materials (categories A,B,C,D,E)
- The plastic nail reduces heat transmission (value 0.0W/K)
- Pre-assembled expansion nail saves time and labour.
- Unique nylon pin design reinforced with glass fibre allows fast and trouble-free installation with correct expansion of the plug.
- Expansion zone designed for low embedment depths, reducing the amount of drilling required.
- Can be used in combination with additional KWL plate - 90, 110 or 140mm diameter.

### Applications

- External Thermal Insulation Composite Systems (ETICS)
- Polystyrene (EPS) boards
- Polyurethane (PU) boards
- Mineral wool (MW) boards
- Lightweight wood wool building boards
- Cork boards

### Base materials

#### Approved for use in:

- Concrete C12/15-C50/60 (Use category A)
- Solid Brick (Use category B)
- Solid Sand-lime Brick (Use category B)
- Hollow Brick (Use category C)
- Vertically-perforated clay block (Use category C)
- Hollow Sand-lime Brick (Use category C)
- Hollow Lightweight Concrete Block (Use category D)
- Lightweight Concrete Block (Use category C)
- Reinforced components of lightweight aggregate concrete (Use category D)
- Aerated Concrete Block (Use category D)

## Installation guide

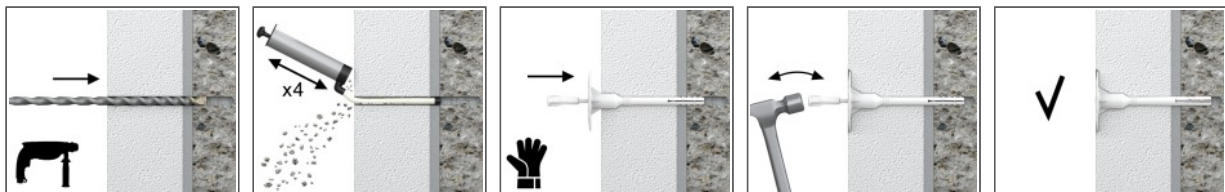

1. Drill a hole of required diameter and depth
2. Clean the hole
3. Bottom side of the plate must be flush with the ETICS.
4. Lightly tap the plastic nail into the plastic sleeve until fixing is secure and flush with insulation material.
5. Embedment depth of min 25 in masonry, perforated materials and lightweight concrete blocks and 65mm in aerated concrete.
6. In soft insulation panels the fixing should be combined with insulation retaining plates KWL-90, KWL-110, KWL-140.

**Product information**

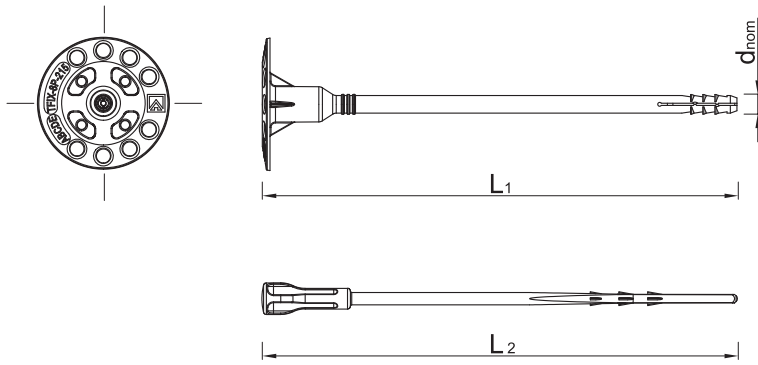

Size	Product Code	Fixing			Fixture	
		Diameter	Length	Plate diameter	Recommended thickness	
		d	L	D	t <sub>fix</sub> A, B, C, D	t <sub>fix</sub> E
[mm]						
Ø8	TFIX-8P-115	8	115	60	80	40
	TFIX-8P-135	8	135	60	100	60
	TFIX-8P-155	8	155	60	120	80
	TFIX-8P-175	8	175	60	140	100
	TFIX-8P-195	8	195	60	160	120
	TFIX-8P-215	8	215	60	180	140

**Installation data**

Substrate			A, B, C, D	E
Fixing diameter	d	[mm]	8	8
Hole diameter in substrate	d <sub>0</sub>	[mm]	8	8
Min. hole depth in substrate	h <sub>0</sub>	[mm]	40	80
Min. installation depth	h <sub>nom</sub>	[mm]	25	65
Min. substrate thickness	h <sub>min</sub>	[mm]	100	110
Min. spacing	s <sub>min</sub>	[mm]	100	100
Min. edge distance	c <sub>min</sub>	[mm]	100	100

**Basic performance data**

Performance data for single anchor without influence of edge distance and spacing

Substrate		Concrete C16/20	Concrete C12/15	Solid brick	Sand-lime solid brick	Perforated ceramic brick	Sand-lime hollow brick	Lightweight concrete 50-lid block	Lightweight concrete hollow block	Lightweight concrete	Autoclaved aerated concrete AAC 6MPa
		Effective embedment depth h <sub>ef</sub>	[mm]	25	25	25	25	25	25	25	25
<b>CHARACTERISTIC LOAD N<sub>rk</sub></b>											
TFIX-8P	[kN]	0.50	0.40	0.50	0.50	0.30	0.30	0.30	0.30	0.30	0.50
<b>DESIGN LOAD N<sub>rd</sub></b>											
TFIX-8P	[kN]	0.25	0.20	0.25	0.25	0.15	0.15	0.15	0.15	0.15	0.15
<b>RECOMMENDED LOAD N<sub>rec</sub></b>											
TFIX-8P	[kN]	0.18	0.14	0.18	0.18	0.11	0.11	0.11	0.11	0.11	0.11

## Basic performance data

Fixing type		TFIX-8P
Plate resistance	[kN]	1.38
Plate stiffness	[kN/mm]	0.3
Point thermal transmittance	[W/K]	0

## Product commercial data

Size	Product Code	Fixing			Quantity [pcs]			Weight [kg]			Bar Codes
		Diameter [mm]	Length [mm]	Plate diameter [mm]	Box	Outer	Pallet	Box	Outer	Pallet	
Ø8	TFIX-8P-115 <sup>1)</sup>	8	115	60	200	200	8000	3.3	3.3	160.0	5906675078267
	TFIX-8P-135 <sup>1)</sup>	8	135	60	200	200	8000	3.5	3.5	171.3	5906675087818
	TFIX-8P-155 <sup>1)</sup>	8	155	60	200	200	6400	3.7	3.7	146.9	5906675092515
	TFIX-8P-175 <sup>1)</sup>	8	175	60	200	200	6400	3.9	3.9	154.1	5906675078274
	TFIX-8P-195 <sup>1)</sup>	8	195	60	200	200	6400	4.0	4.0	156.7	5906675088228
	TFIX-8P-215 <sup>1)</sup>	8	215	60	100	100	4000	2.4	2.4	124.7	5906675086514

1) ETA-13/0845